

Description

The type CRD-01 Gas Retention Damper has been specifically designed to meet the rigorous duty required in an environment where robust construction and dependable operation are of prime importance.

These versatile dampers are suitable for automatic and manual operation and are used for retaining the release of an inert gas extinguisher during a high temperature event.

To ease installation all dampers are supplied with pre-drilled flanges and are designed to be suitable for mounting in any attitude with the airflow in either direction.

Specification

Casing

The damper casing is formed from 3.0 mm thick sheet steel into a rigid channel section to ensure proper alignment of blades and shafts. Damper units in excess of 1275 mm width shall be manufactured as a multiple assembly. Where circular dampers or dampers with width or height dimensions less than 150 mm are required, additional spigot adaptors are used which increase the damper insertion length from 300 to 400 mm.

Blades

The blades are a formed double-skin aerofoil section of 1.5 mm sheet metal with stainless steel edge seals. Blade stops at the top and bottom of the casing and sprung side seals provide excellent low leakage characteristics.

Shafts

Continuous \varnothing 19.05 mm with blades plug welded at each end.

Linkage

Parallel action linkage consisting of drive levers and bosses connected by flat bar link bars, driven through stainless steel pins. All linkage is contained within the depth of the damper casing.

Bearings

Phosphor bronze self lubricated 'Oilite' flanged bushes.

Operation

Pneumatic Actuator, Manual Latching Mechanism, Electric operation unavailable on this damper type.

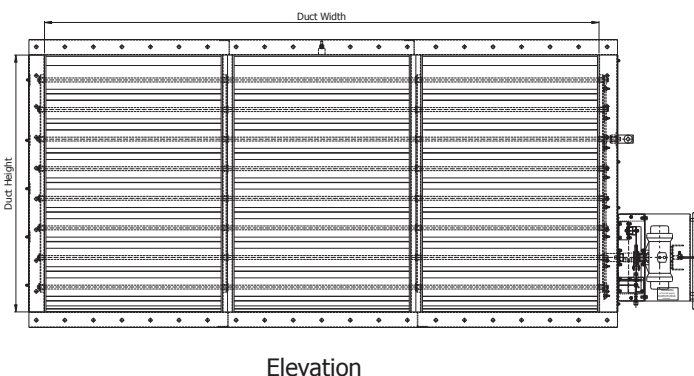
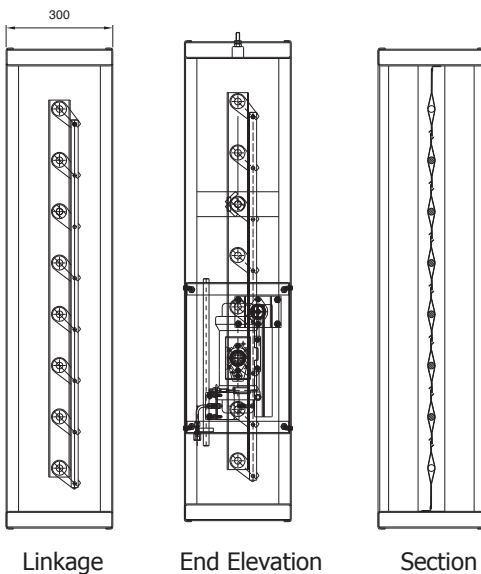

Options

- Materials can be stainless steel, galvanized mild steel or other materials to suit the clients' specific requirements
- Earth continuity bosses.
- Lifting lugs.
- Integral or removable enclosures for housing control equipment.
- High temperature bearings.
- Shaft seals to provide airtight casings
- Other variations to suit clients' specific requirements are also available.

Gas Retention Damper

CRD-01

Installation & Assembly

Note:

Larger dampers can be constructed by joining multiple assemblies together.

An approved fire-resistant sealant should be inserted between the damper and duct to ensure a good seal.

Note:

Each section shall have a drive spindle which can be linked together externally or driven independently.

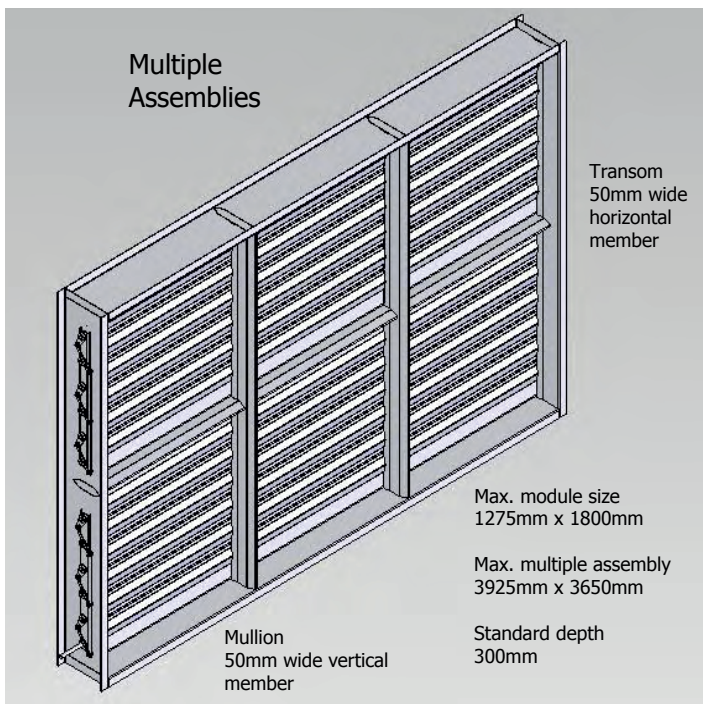
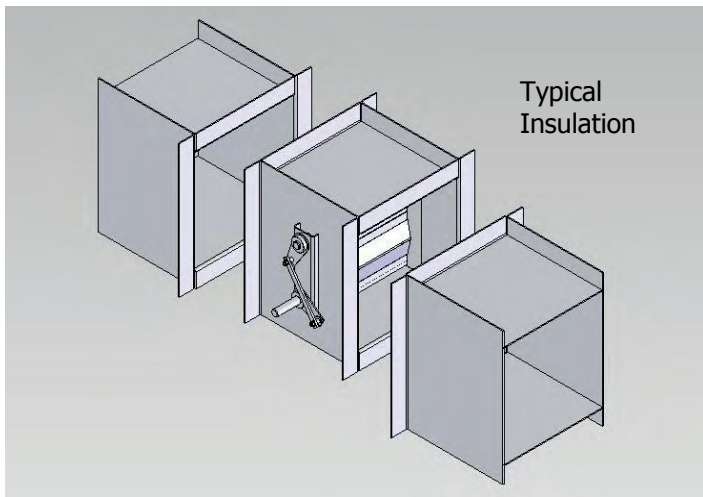

Leakage Characteristic Curve

Tolerance $\pm 15\%$

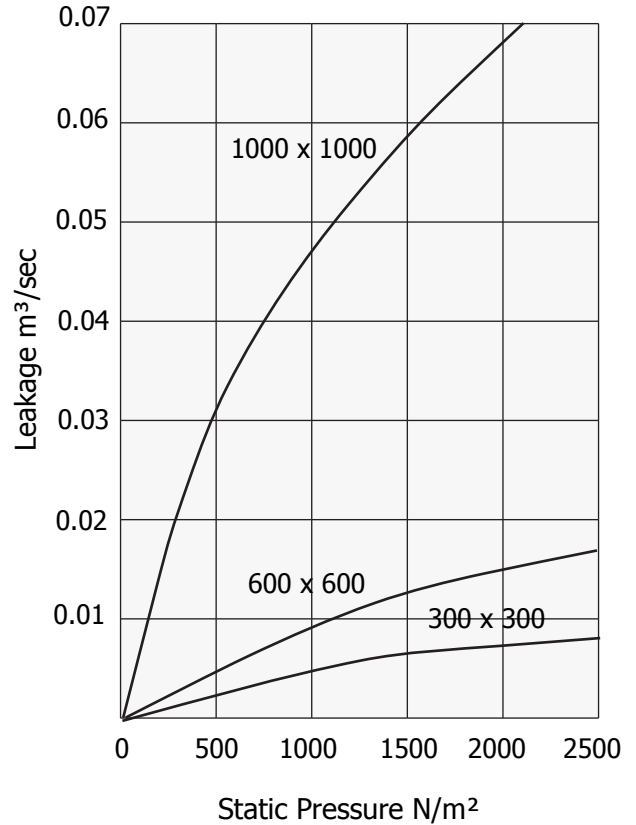

Open Pressure Drop Characteristic Curve

Tolerance $\pm 15\%$

